

K31 XZ

TRUCK-MOUNTED CONCRETE BOOM PUMP

Placing boom
Pumping unit

B5Z 31/27
PA907F8, PA1206F8
PA1506/909F8
HPG 1808/1113IF8-IF9
PTO
3 - 4 axles

Driven by
Chassis



Dimensions

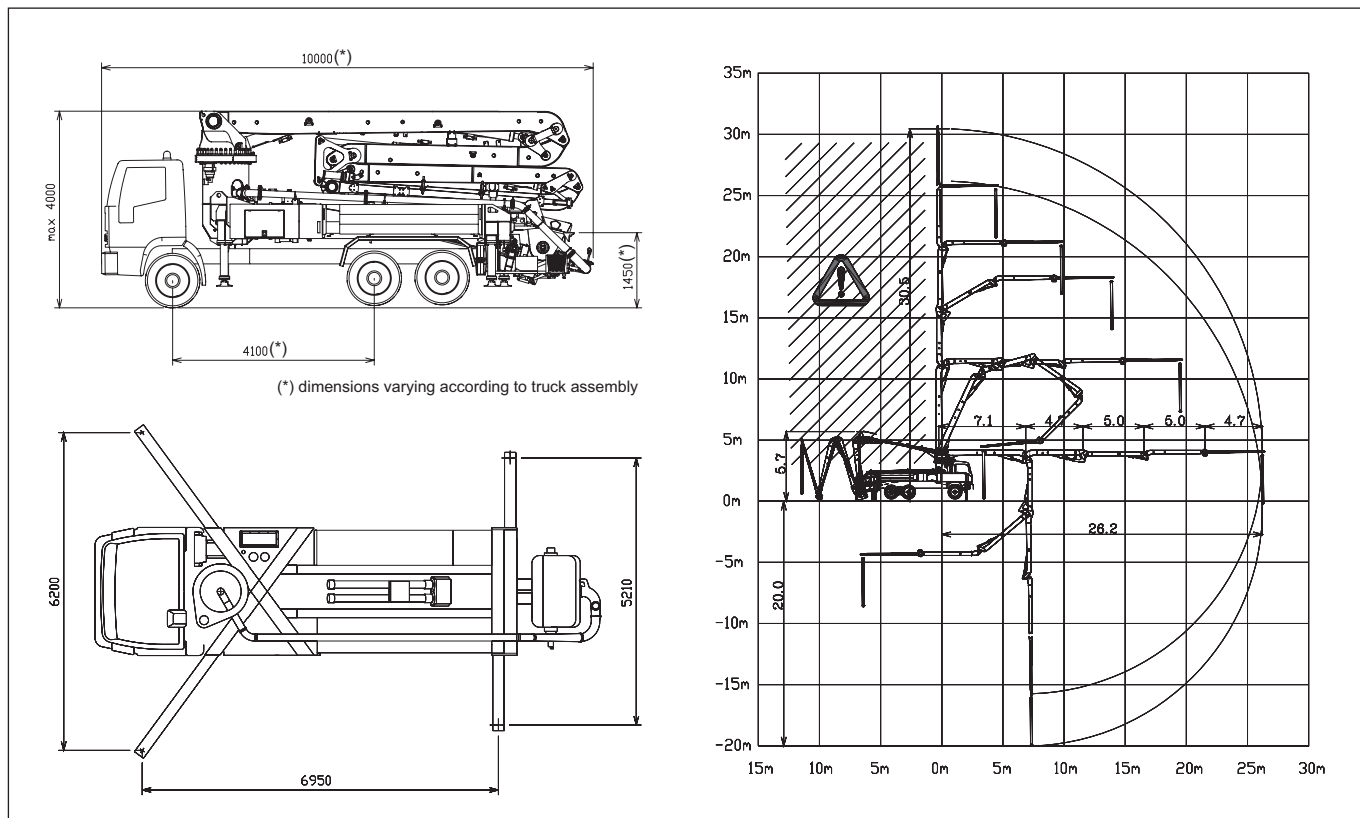

K31 XZ

Main features

- Advantageous assembling on standard 3 - 4 axle chassis
- Self-supporting frame - torsion free FEM designed
- Placing boom B5Z 31/27, 5 sections, 125 mm pipeline diameter, "Z" folding system and continuous rotation on 5th section
- Fully hydraulic outrigger controls on both sides of the truck
- Front outriggers "X" style for a quick set-up and easy pump placement in narrow areas
- Proportional boom control
- The "BFC" Best-Flex Cifa supporting system allowing just one man to change delivery pipeline easily, quickly and safely
- Concrete flow rate regulator
- F8 pumping system with open circuit: smooth, continuous and easy movements, combined with high reliability.
alternatively:
HPG-IF pumping unit with closed circuit and reversal flow: superb performances, high pressures and output, high reliability and easy and reduced maintenance; alternative of 9 inches S valve
- Safety device on opening inspection hatch

Standard equipment

- Proportional radiocontrol system with two speeds for the boom, frequency synthesizer, 8 position keypad and concrete flow rate regulator
- Proportional remote control for emergency with 8 position keypad, concrete flow rate regulator and 30 m cable
- Emergency control pad for pumping unit HPG 1808/1113IF
- Remote controlled electric vibrator placed on the concrete hopper grid
- Centralized lubrication system for pumping unit
- Automatic oil lubrication system for pumping pistons on HPG 1808/1113IF
- Additional manual lubrication system for pumping unit
- Hard plastic outrigger support plates with relative housing
- Rear light on hopper
- Level readers for stabilization control
- Accessories for cleaning and pipes washing
- Aluminium hopper covering

Optionals

- Double thickness concrete pipes, in high resistant steel
- High pressure water pump for cleaning
- Air compressor for pipeline cleaning
- Centralized lubrication system for placing boom
- Air pipeline for placing boom
- Separated emergency engine kit for independent control of the hopper mixer, concrete pumping unit, boom and water pump

TRUCK-MOUNTED CONCRETE BOOM PUMP

**Placing boom
Pumping unit**

B5Z 31/27
PA907F8, PA1206F8
PA1506/909F8
HPG 1808/1113IF8-IF9

**Driven by
Chassis**

PTO
3 - 4 axles

Pumping unit technical data

MODEL		PA 907 F8	PA 1206 F8	PA 1506/909 F8	HPG 1808/1113 IF8-IF9
Max. theoretical output	<i>m³/h</i>	87	120	150/90	179/105
Max. pressure on concrete	<i>bar</i>	73	53	53/95	76/130
Max. numbers of cycles per min.	<i>nr.</i>	31	24	30/17	36/21
Conc. cylinders (diam. x stroke)	<i>mm</i>	200x 1500	230x 2000	230x 2000	230x 2000
Concrete hopper capacity	<i>l</i>	550	550	550	650
Hydraulic circuit		open	open	open	closed

Placing boom technical data

MODEL	B5Z 31/27	
Pipeline diameter	<i>mm</i>	125
Max. vertical reach	<i>m</i>	30,5
Max. horizontal distance	<i>m</i>	26,2
Min. unfolding height	<i>m</i>	5,7
Section numbers		5
1st section opening angle		90°
2nd section opening angle		180°
3rd section opening angle		240°
4th section opening angle		180°
5th section opening angle		continuous
Rotating angle		370°
End hose length	<i>m</i>	4

Technical data and characteristics subject to modifications.