

## KT28

### Stationary placing boom

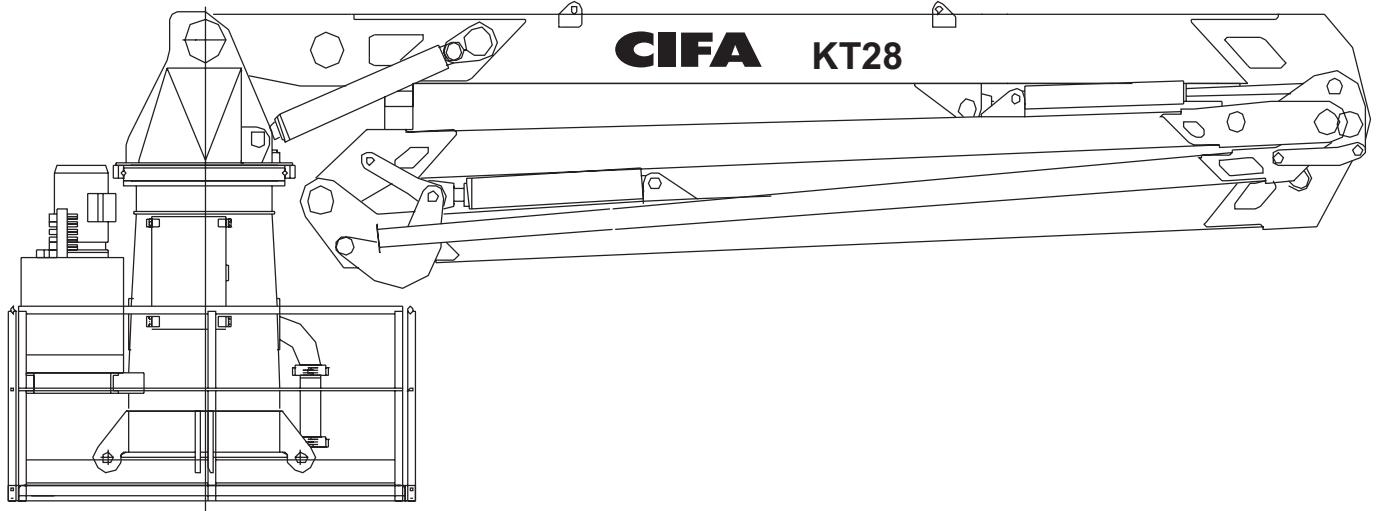
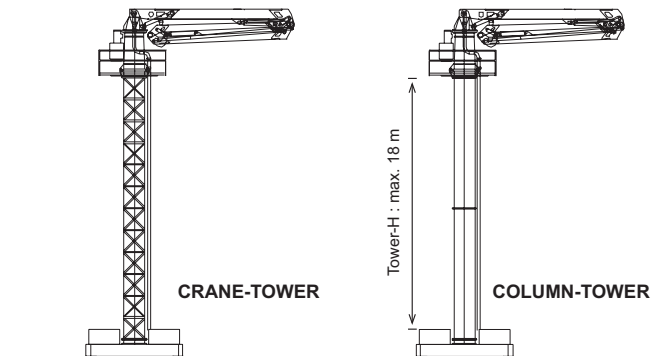
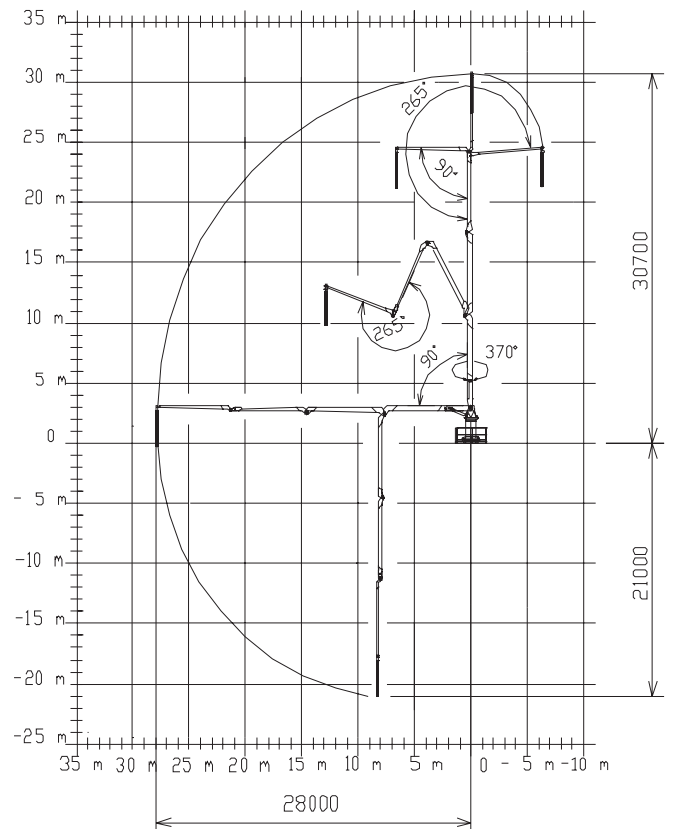
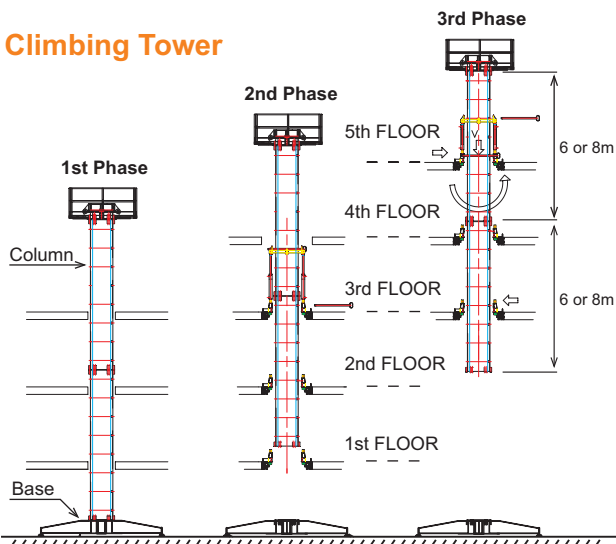

Diagram of placing boom performance and tower application

#### Stationary Tower



#### Climbing Tower



# KT28

## Stationary placing boom

### Placing Boom

Four sections, with "Roll' n' fold" folding system. The boom movement is hydraulically operated. The reduction gear, which operates the boom rotation, is fitted with two safety devices: a parking brake which operates when the pressure in the circuit stops; a safety valve which prevents the rotation when the oil flow from the hydraulic pump stops. The boom sections operate by lever articulation joints, driven by hydraulic jacks fitted with special "over-center" valves which act two functions: maintenance of placing boom position in normal and emergency conditions; safety against accidental overloads, by direct discharge to the tank

### Structure / Assembly

Compact boom with high performances, studied for a perfect handling of the sections, in order to reach every extremeworking point easily. Quick, easy and safety assembling/disassembling operations

### Boom Electrohydraulic Gearcase

Unit positioned into the tower-boom area. Electric motor 20kW-380 V/50 HZ. Oil tank capacity 300l

### Stationary Tower

Ballasted basement to obtain the stabilization by crossed ("X" style) beams, "H-E-A" sections (ballast excluded), carried out by two modules in clearance gauge for transport.

Foreseen versions :

- **Crane-tower**, supplied by customer, under Cifa's technicians supervision, in accordance with International Safety Standard Rules. Max. assembling heights even higher than 18m. Adaptor unit be defined by customer
- **Column-tower**, assembled with flanged tubular section-modules (length 2-3-6m ), for max. 18 m high

The column-tower model is complete with access ladder to the control platform.

Module suitable for fast connection, between the tower-body (column/crane) and the structure of stationary placing boom

Technical data Stationary boom KT28		B5R-28
Pipeline diameter	mm	125
Max. horizontal reach (from the slewing axis)	m	27,8
Max. depth reach (with tower-H up to 18 m)	m	24,4
Section length : - 1st + 2nd	m	7,67 + 6,90
- 3rd + 4th	m	6,75 + 6,50
Section number		4
Rotating angle		370°
Station. tower height (crane/column)	m	18
Installed power	kW	20
End-hose length	m	4
Static tilting moment	Kgm	65.500
Module + station. boom weight	Kg	8.200

### Climbing Tower

#### Mounting on a self-mounting tubular column

Using the existing bases slabs as a support, the boom and the column lift themselves hydraulically through special openings in the levels. Anchoring is done using special support frames and contrast grips.

The system consists of:

- Base pedestal for anchoring to the foundations
- Modular tubular column section with modules 6+6m and 8+8m long connected using bolts
- Ladder in 2m elements
- Working platform around the top of the column
- Guide frames and fixing on three levels
- Hydraulic lifting system for the column and boom consisting of 2 lifting cylinders and 2 locking pins
- Climbing tower electrohydraulic gearcase 380V-50Hz / 7,5kW
- Minimal distance between the levels 3m
- Climbing speed max 1m/1'

### Standard Equipment

- ø 125mm delivery pipeline, standard length 3m
- End hose 4 m long
- "ON-OFF" remote control with 8 positions keypad 35m cable
- Electric control panel
- Subturret-module for anchoring to column/crane
- Antislip floor pan and ladder
- Box for accessories
- One colour painting
- Vertical concrete piping on column-tower side

### Optionals

- "HAWE" proportional control system for placing boom
- "HETRONIC" proportional radiocontrol system
- Tower and boom supply in two modules to allow the assembling with crane max. pull-loads 5000Kg
- Basement with anchor-bolts
- Twin Pipes®

Technical data and characteristics subject to modifications without notice