

Cod. 228681/B

LUBRICATION

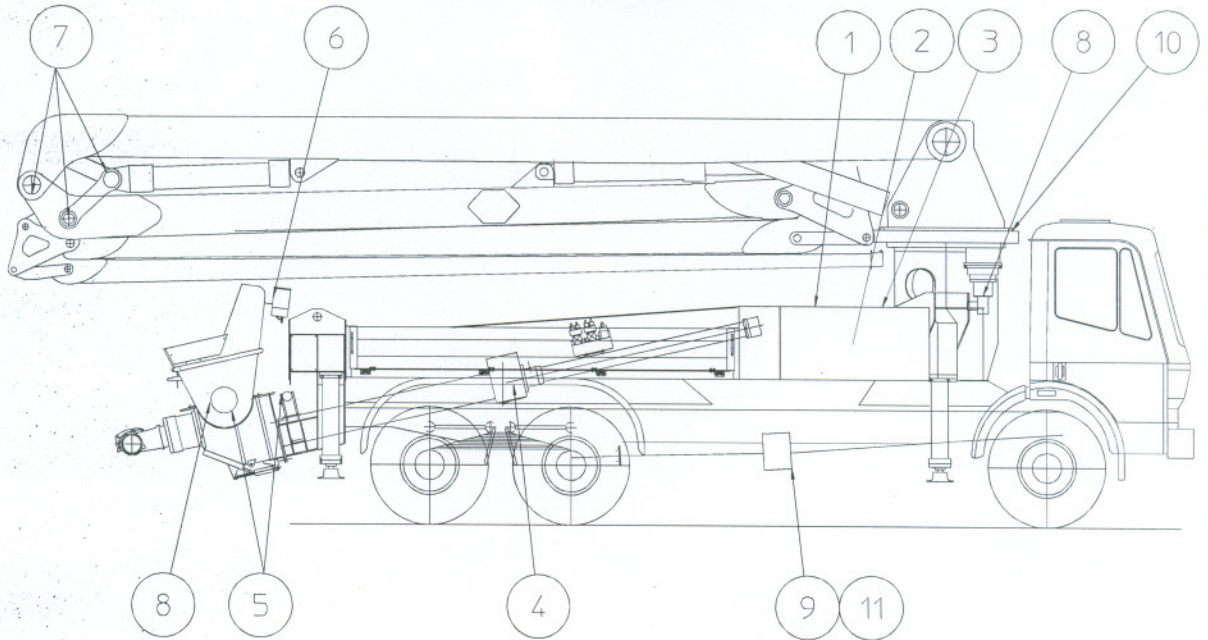

POS	REFERENCE	LUBRICATION INTER-VALS (hours)					LUBRICANTS	REMARKS
		25	50	200	500	2000		
1	TANK EXHAUST FILTER			S				DEPENDENT ON ENVIRONMENTAL CONDITIONS
2	HYDRAULIC OIL IN THE TANK		C			S	ESSO HYDRO HVI 46 UNIVIS N46	WITHIN 1 YEAR MAX
3	RETURN FILTER				S			1st REPLACEMENT AFTER 200 h
4	LUBRICATING WATER FOR CONCRETE CYLINDERS						WATER	DAILY REPLACEMENT
5	VALVE CYLINDER AND MIXER SHAFT ARTICULATIONS		I				ESSO BEACON EP 2	GREASE NLGI 2
6	GREASE PUMP		C				ESSO BEACON EP 2	GREASE NLGI 2
7	ARTICULATIONS FOR BOOM SECTIONS AND EXTRACTABLE OUTRIGGERS		I				ESSO BEACON EP 2	GREASE NLGI 2
8	MIXING SHAFT REDUCER		C			S	ESSO SPARTAN EP 150	1st CHANGE AFTER 100 h WITHIN 1 YEAR MAX
9	OIL FOR POWER-TAKE-OFF		C			S	ESSO SPARTAN EP 150	1st CHANGE AFTER 100 h WITHIN 1 YEAR MAX
10	BOOM ROTATING GEAR		I				ESSO BEACON EP 2	GREASE NLGI 2
11	AUXILIARY ENGINE						SEE USE AND MAINTENANCE BOOK	AS PER MANUFACTURER'S INSTRUCTIONS

S = REPLACE

C = CHECK LEVEL AND REFILL

I = GREASE